

Typ 180 A

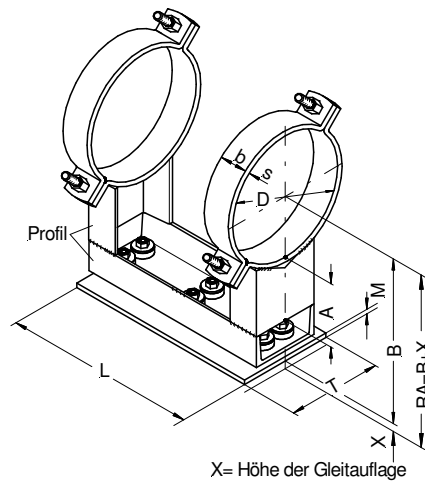

Typ 180 A Form H
mit Abhebesicherung



Bitte berücksichtigen Sie bei der Planung die Bauhöhe X eventueller Gleitauflagen

D	b x s	A	B+/-2	L	M	T		Schrauben	Profil
						180 A	180 AH		
26,9	30x5	90	142	180	8	40	90	M10x30	40x20
33,7	30x5	90	145	180	8	40	90	M10x30	40x20
42,4	30x5	90	149	180	8	40	90	M10x30	40x20
44,5	30x5	90	150	180	8	40	90	M10x30	40x20
48,3	30x5	90	152	180	8	40	90	M10x30	40x20
57,0	40x6	100	167	240	8	40	90	M12x40	40x20
60,3	40x6	130	203	240	8	50	100	M12x40	50x25
76,1	40x6	130	216	240	8	60	110	M12x40	60x30
88,9	40x6	130	223	240	8	60	110	M12x40	60x30
108,0	50x8	130	247	250	8	80	130	M16x50	80x45
114,3	50x8	130	250	250	8	80	130	M16x50	80x45
133,0	50x8	130	260	250	8	80	130	M16x50	80x45
139,7	50x8	130	263	250	8	80	130	M16x50	80x45
159,0	50x8	130	278	250	8	100	150	M16x50	100x50
168,3	50x8	130	282	250	8	100	150	M16x50	100x50
219,1	50x8	130	313	350	8	120	170	M16x50	120x55
273,0	60x8	130	340	350	8	120	170	M20x60	120x55
323,9	60x8	130	370	360	8	140	200	M20x60	140x60
355,6	60x8	130	386	360	8	140	200	M20x60	140x60
406,4	80x8	130	411	390	8	140	200	M24x70	140x60

Alle Maße in mm